

BOTTOM VIEW

FRAME AND COVER – PLAN VIEW

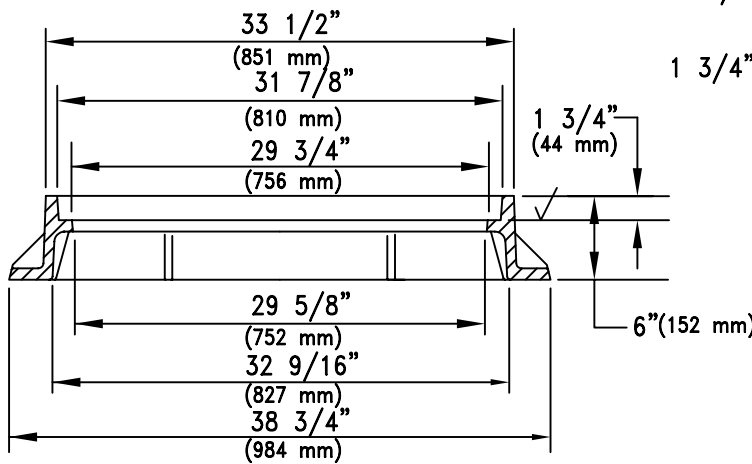

FRAME SECTION A-A

√ DENOTES MACHINED SURFACE

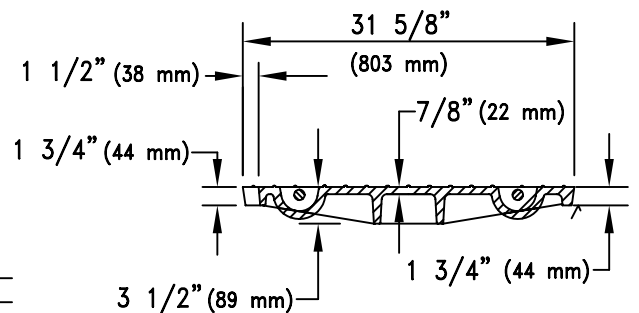

COVER SECTION

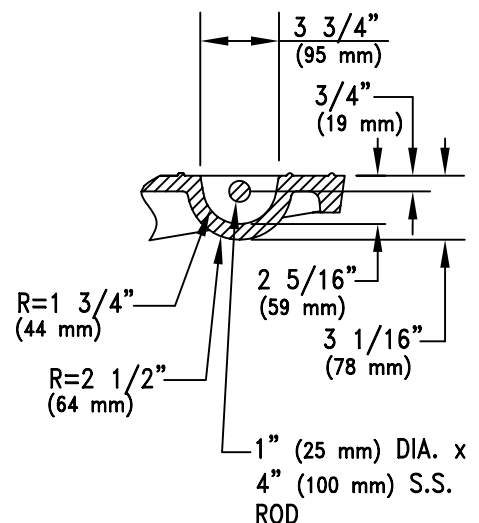

PICKBAR RECESS DETAIL

NOTES:

1. REFER TO GENERAL NOTES, STD. DET. WWM 213.0.
2. DETAIL FOR MANHOLES OF MAINS OF 27" (675 mm) DIAMETER OR LARGER.
3. THE COVER SHALL HAVE RECESSES FOR PICK BAR. VENT HOLES SHALL NOT BE PROVIDED.
4. FRAME WEIGHT 200 LBS. (91 kg.) (APPROX.).
5. COVER WEIGHT 217 LBS. (98 kg.) (APPROX.).

ISSUED:		STANDARD DETAIL		DETAIL NO.
8/92		30" (760 mm) WATERPROOF		WWM 214.1
REVISED:		MANHOLE FRAME		SHEET 1 OF 1
1/02		AND COVER		