

BOTTOM VIEW

FRAME AND COVER - PLAN VIEW

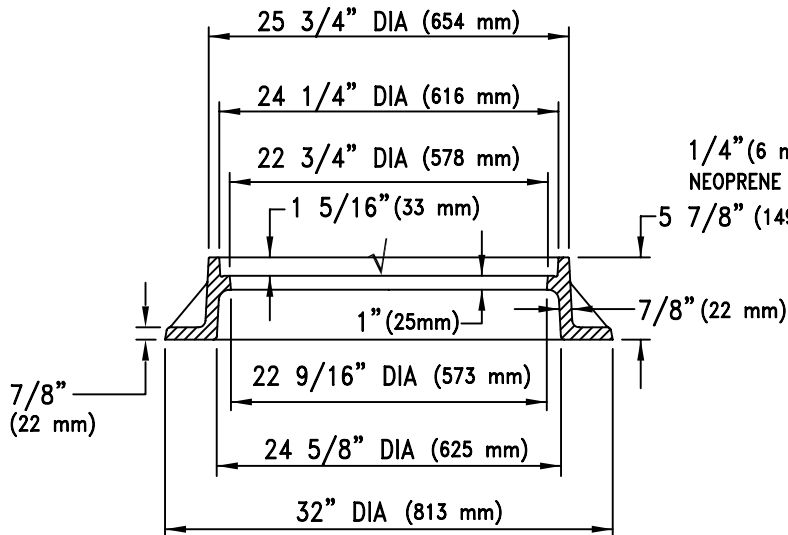

FRAME SECTION A-A

√ DENOTES MACHINED SURFACE

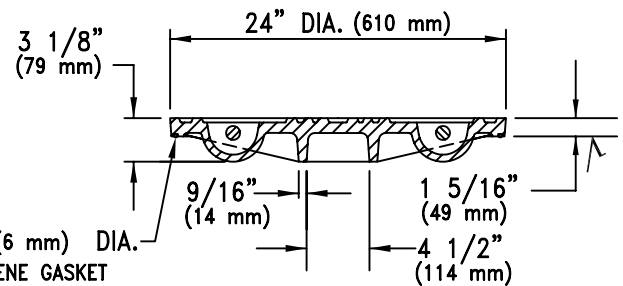

COVER SECTION

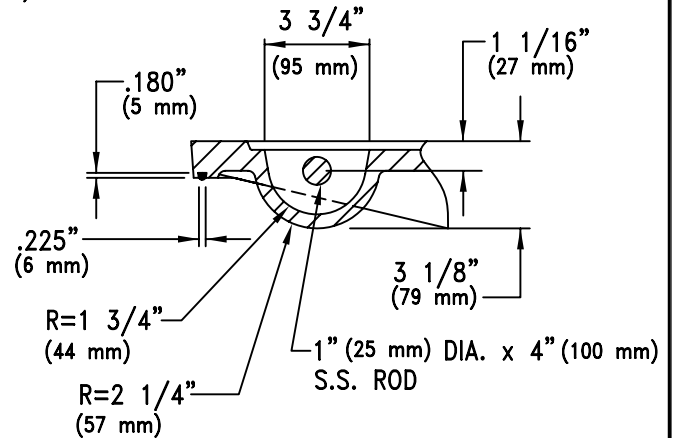

PICKBAR RECESS DETAIL

NOTES:

1. REFER TO GENERAL NOTES, STD. DETAIL WWM 213.0.
2. THE COVER SHALL HAVE PICKBAR RECESSES AS DETAILED HEREIN. VENT HOLES SHALL NOT BE PROVIDED.
3. FRAME WEIGHT 180 lbs. (82 Kg) (APPROX.).
4. COVER WEIGHT 130 LBS. (59 Kg) (APPROX.).

ISSUED:		STANDARD DETAIL		DETAIL NO.	
8/92		24" (610 mm) WATERPROOF MANHOLE FRAME AND COVER		WWM 213.2	
REVISED:					SHEET 1 OF 1
7/02					